



Bicycle Facility Selection Guide

Development Services
Committee

January 24, 2012



Contents

Purpose of The Selection Guide

The Three - Step Process

Bikeway Facility Types



Purpose of the Selection Guide

Cycling facility planning and design has been evolving rapidly, even since the Town's Cycling Master Plan was completed.

- There is no “formula” for appropriate bicycle facility selection
- It is a process that combines an analysis and understanding of the conditions of the location being considered with sound engineering judgement

The **Bicycle Facility Selection Guide** can be used to assist Town staff in selecting appropriate bicycle facilities for Town-owned local and collector road rights-of-way.



Bikeway Facilities in Road Rights-of-Way

Things to Remember

- Cyclists vary widely in levels of skill, experience and confidence
- No single type of bicycle facility design will suit every cyclist
- Engineers need to gather information on existing and future conditions in order to identify cyclist needs and safety concerns for a given location
- The choice to provide a separated versus non-separated facility is not a simple “yes or no” answer, it is based on the consideration of a number of factors described in the slides that follow
- Criteria or thresholds to select one facility type over another need to be flexible to be able to accommodate each site’s unique set of circumstances
- No facility design can overcome a lack of operator skill or lack of attention



Markham's Cycling Network



Cycling Master Plan
(2007)

Figure 2-6
Draft Routes by
Facility Type

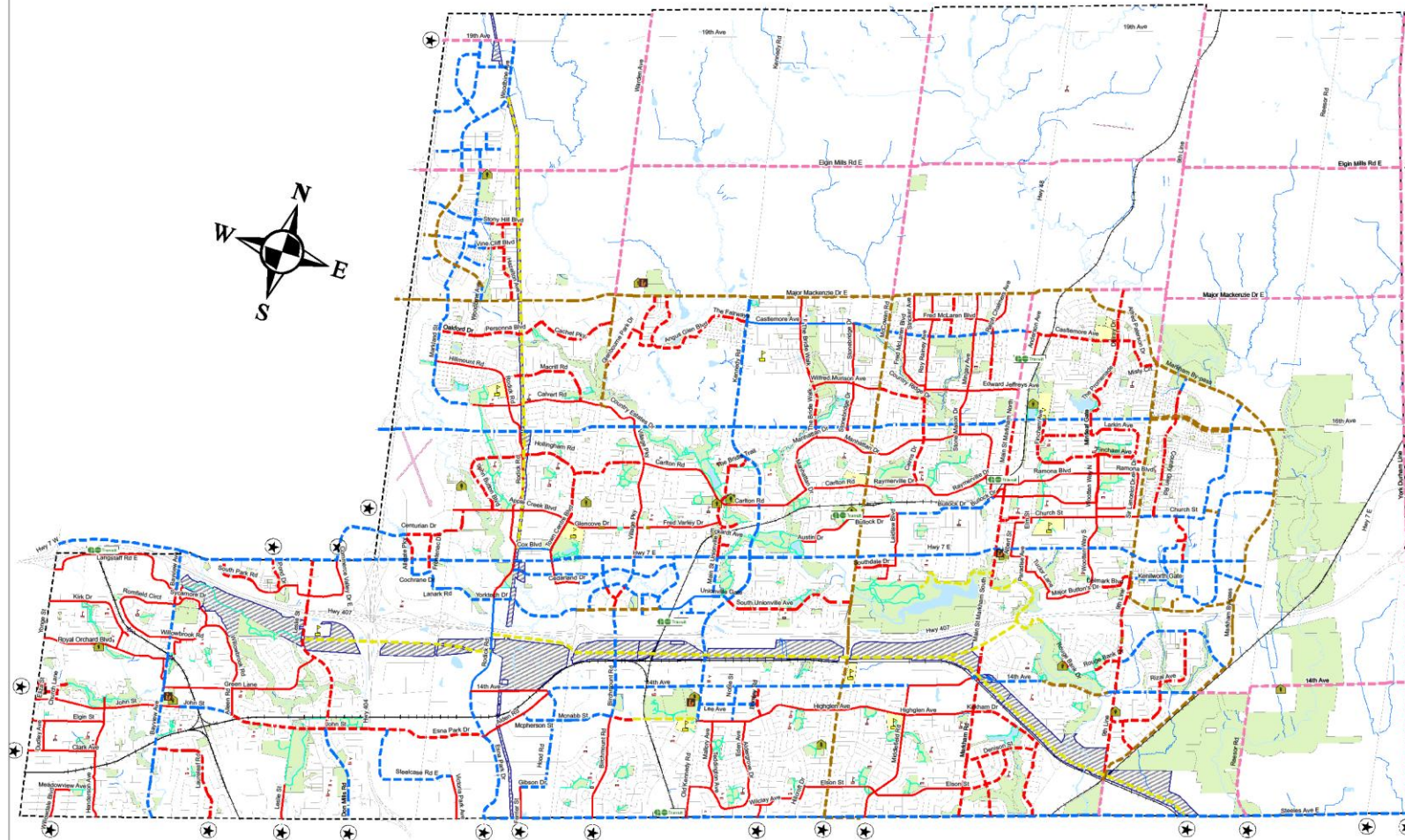

Legend

- Municipal Boundary
- Existing trail underpass
- Gateway to existing or proposed Municipal bike networks
- Roads
- Trails
- Railway
- Airport runway
- Park and Open Space
- Schools
- Hydro corridor
- High school
- Elementary school
- Community Centre
- Library
- Go Station

Cycling Network

Existing

- Existing Signed-only Route
- Existing Bike Lane

Proposed

- Paved Shoulder Bikeway
- Signed-only Route
- Bike Lane*
- Off Road (Boulevard Trail)
- Trail in Utility/Greenway Corridor

Note:
All Off-Road trail alignments outside of road rights-of-way to be confirmed through Town's Recreational Trail and Pathway Study.

* The proposed bike facility on Steeles Ave. falls under the jurisdiction of the City of Toronto and is displayed for information purpose only.

Draft

April, 2007



The Three - Step Process

Step 1: Pre-selection Nomograph

- Collect and review existing and future traffic volume and motor vehicle operating speed data
- Plot on Nomograph
- Nomograph provides a general guide for facility types to be considered

Step 2: Examine Other Factors

- Skill level of anticipated users (e.g. novice/recreational vs. skilled/utilitarian)
- Number of lanes
- Traffic characteristics
- Number and frequency of potential conflict points (e.g. driveways/entrances and road intersections)
- Adjacent land uses and lot patterns
- Frequency of transit stops
- Pedestrian safety
- Urban Design
- Collision patterns
- Complexity of intersections
- On-street parking where applicable (e.g. configuration, demand, turnover)
- Directness and connectivity with other cycling facilities and type of cycling facility at connecting points
- Type of trip generators/destinations along the route being examined
- Pinch points (e.g. bridges, retaining walls etc.)
- Topography and sight lines
- Operations and maintenance
- Surface quality, etc.

Step 3: Select Appropriate Facility Type

- Based on results from Steps 1 and 2, plus sound engineering judgement

Step 1- Pre-Selection Nomograph

Source: MRC-Delphi, 2011 (a member of the MMM Group)

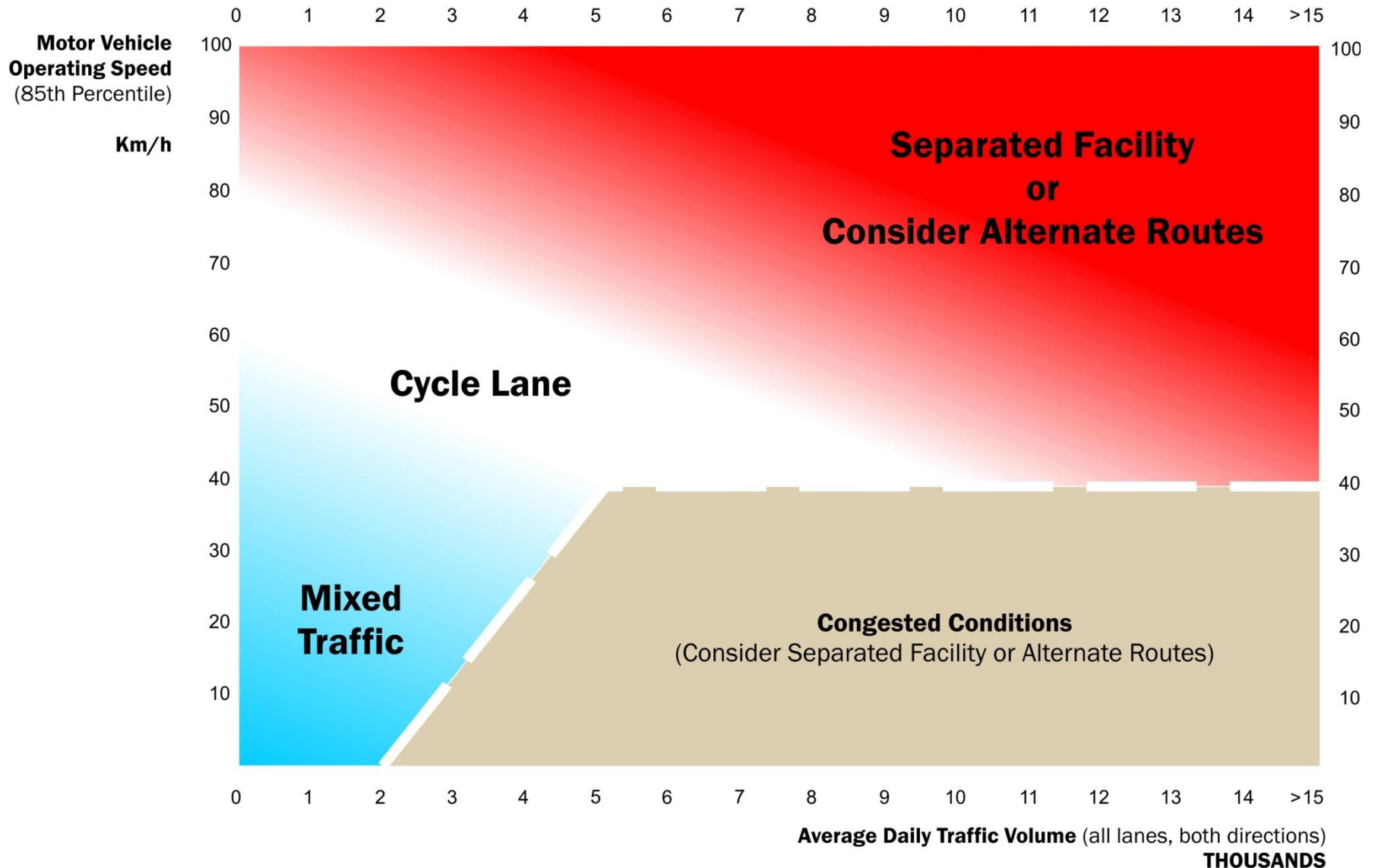



Step 2: Some Things To Consider When Examining Factors

Anticipated Users and Skill Levels

- It is usually easier to accommodate the needs of commuter cyclists on roads than on pathways. Commuters generally prefer direct continuous facilities with minimal delay, and when riding on collector and arterial roads, cyclists tend to be more comfortable on separated bike facilities such as bike lanes, buffered bike lanes or some other form of separation.
- Novice and recreational users prefer routes along quieter streets where traffic volumes and speeds are lower, even if these routes are less direct. They also prefer separated facilities.
- Consider what facility types exist or are planned at the end points of the segment that is being assessed. Continuity of facility type is desirable. If this cannot be achieved, carefully select appropriate transition points and designs.



Some Things To Consider When Examining Factors

Traffic Characteristics and Vehicle Mix

- Where operating speeds are very low (i.e. under 30km/hr.) bicycles and motor vehicles travel at nearly the same speed and formal bicycle facilities may not be necessary.
- Where speed differential between motor vehicles and bicycles is less than 20km/hr. full integration (sharing the road) may be acceptable.
- Where speed differential is greater than 40km/hr., more separation is desirable.
- Where vehicle operating speeds are very high, facilities should be separated by a buffer. Alternatively, a parallel route should be sought.
- Where heavy commercial vehicle and/or transit volumes are high, consider wider on-road bicycle facilities or consider separated facilities.



Some Things To Consider When Examining Factors

Number and Frequency of Potential Conflict Points and Adjacent Land Uses

- Collision statistics suggest that cyclists using boulevard trails are more frequently involved in bicycle/motor-vehicle collisions at intersections compared to cyclists riding on road (e.g. in a bike lane).
- Rear-lotted properties may be good candidates for in-boulevard multi-use pathways provided that the number of private entrances and/or road intersections is low.
- Shared multi-use pathways in road boulevards will increase the exposure to risk/potential for conflicts between pedestrians and cyclists. The potential for conflict may be higher where the pathway is more frequently used by commuter cyclists and/or where pedestrian densities are high.



Some Things To Consider When Examining Factors

On-Street Parking

- Removing on-street parking to add bicycle lanes can result in resistance from local land owners even if the demand for on-street parking appears to be low.
- Where parking demand is low, examine opportunities to remove, restrict or relocate parking.
- Where parking turnover is high, additional buffer space between parking and bike lanes should be considered.
- Bike lanes should not be implemented adjacent to perpendicular or angle parking unless parking can be reconfigured.

Document the analysis upon examining other factors as this supports the rationale for facility selection.

This is especially important when the facility type selected lies at the margins or outside the facility type suggested by the nomograph in Step 1.



Step 3- Select Bikeway Facility Type

Shared Space

- Signed-only Cycling Routes on a Local Road (pg. 14)
- Signed-only Cycling Routes on Wide Outside/Curb Lane (pg. 15)
- Bikeway Boulevards (pg. 16)
- Edge Lines (pg. 17)
- Sharrow Markings (pg. 20)
- Paved Shoulders (pg. 22)

Dedicated Space

- Bike Lanes (pg. 23)

Separated Facilities

- Buffered Bike Lanes (pg. 28)
- Cycle Tracks (pg. 29)
- In-Boulevard Multi-use Pathways Within the Road Right-of-Way (pg. 33)
- Multi-use Pathways Outside the Road Right-of-Way (pg. 34)

**Generally Lower Volume,
Lower Speed
Less Facility Separation**

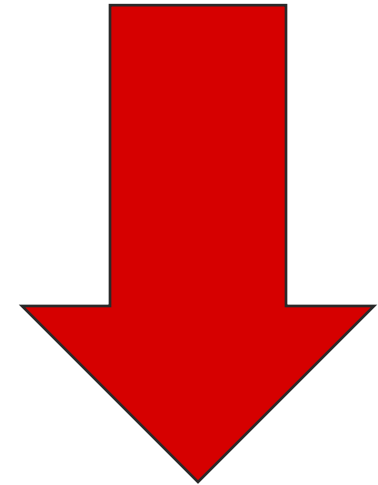

**Generally Higher Volume,
Higher Speed
Greater Facility Separation**



Bikeway Facility Types

Signed-only Cycling Routes on a Local Road (Shared Space)

Signed-only bicycle routes on local roads should be supported by education programming for both cyclists and motorists.

Routes should use appropriate and consistent designation bicycle route sign types, supplemented by “Share the Road” signs.



Shared space on a local road
Elora, ON

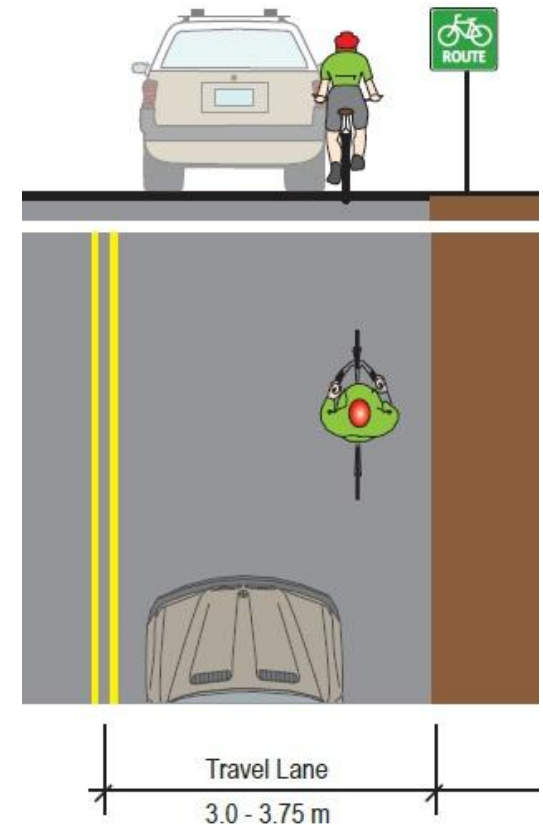

Signed-only Cycling Routes on a Wide Outside/Curb Lane (Shared Space)

Signed-only bicycle routes on wide local roads or lower volume collector roads provide shared space for cyclists and motor vehicles.

Can often be retro-fitted on a 4-lane cross-section by narrowing the inside travel lanes.

Consider “Share the Road” signs and/or sharrow markings at pinch points to make both cyclists and motorists aware of narrow zones.



Shared space on a wide lane
Elora, ON

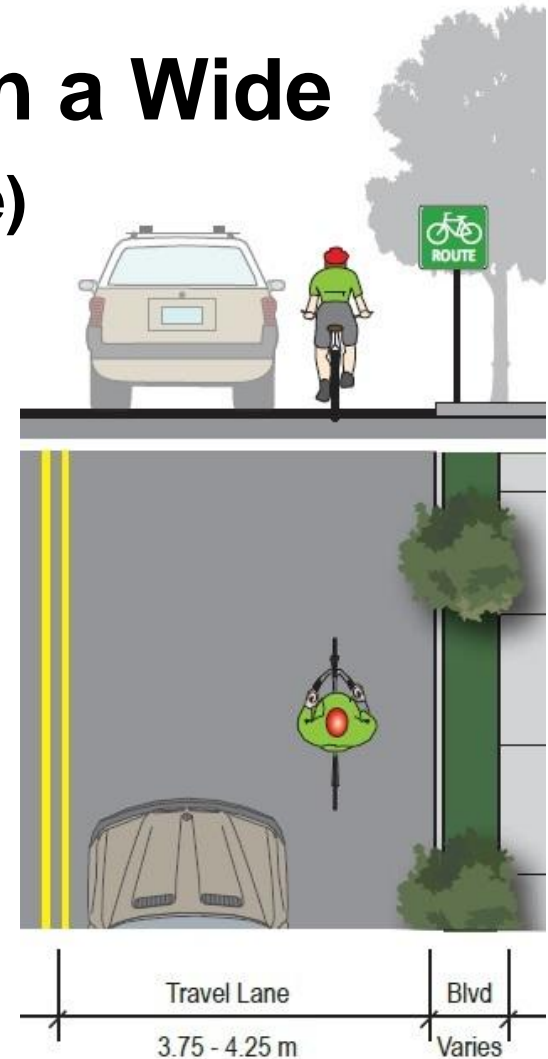

Bikeway Boulevards (Shared Space)

A signed-only bicycle route on local roads that usually parallels an arterial road with important destinations.

Design strategies and elements are employed to encourage through-travel for cyclists and enable them to maintain momentum, yet discourage or restrict through travel by motorists.

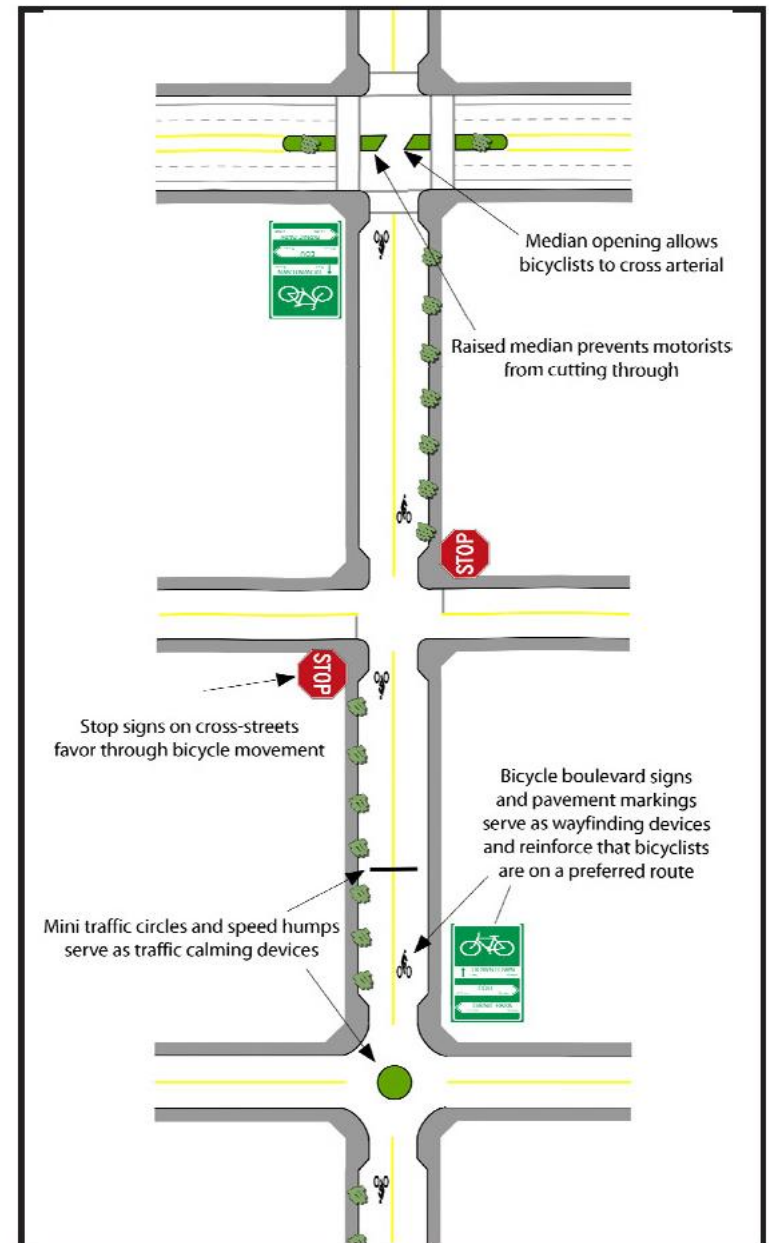
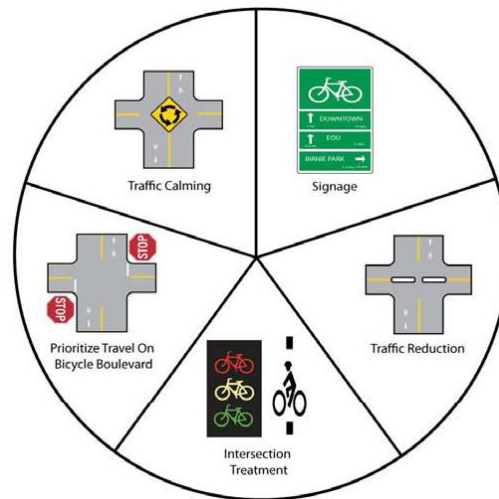

Source: Fundamentals of Bikeway Boulevard Planning and Design, 2009

Edge Lines (Shared Space)

Signed-only cycling routes may be supplemented with edge lines.

Edge lines are primarily added for traffic calming purposes, but may also benefit cyclists.

On-street parking is usually not disrupted

In some instances this may be a useful first step towards implementing future bike lanes where the removal of on-street parking is an issue with neighbouring residents, yet parking demand is low.



Retro-fitting for Edge Lines (Georgetown ON)



11.25m

Retro-fitting for Edge Lines (Georgetown ON)



1.5m

3.8m

3.8m

1.5m

Sharrow Markings

(Shared Space)

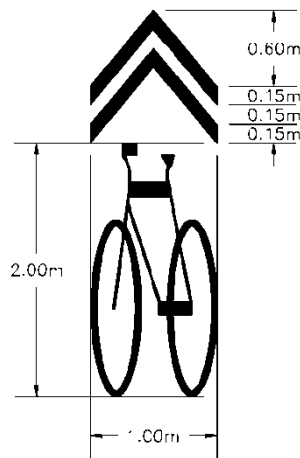
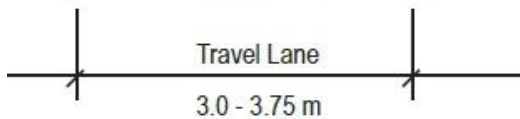
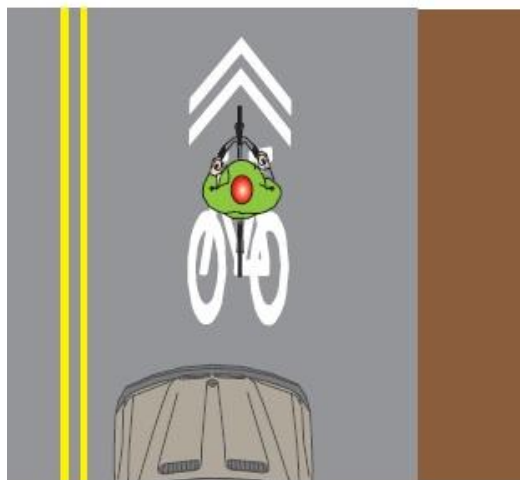

Clear pavement markings and signs illustrate the concept of “share the road” within space-confined roadways.

Pavement markings indicate appropriate positioning for cyclists. Cyclists align their front wheel with the point on the chevron.

Especially useful in congested areas where traffic is generally moving slowly (e.g. a “downtown” street).

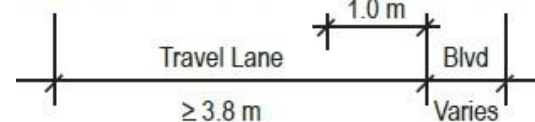
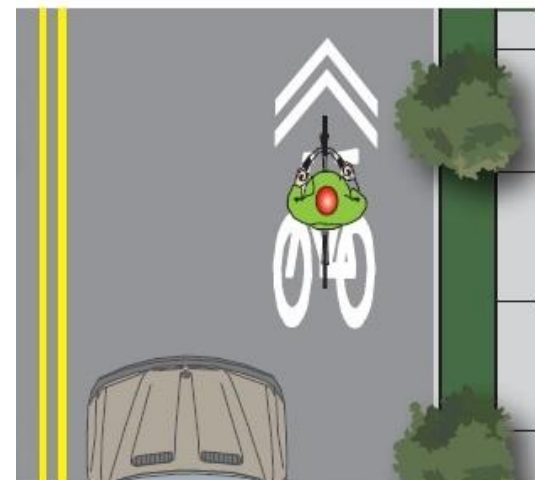

Sharrow Markings

(Shared Space)

Without On-street
Parking



Offset encourages cyclists to maintain an appropriate distance from the curb.

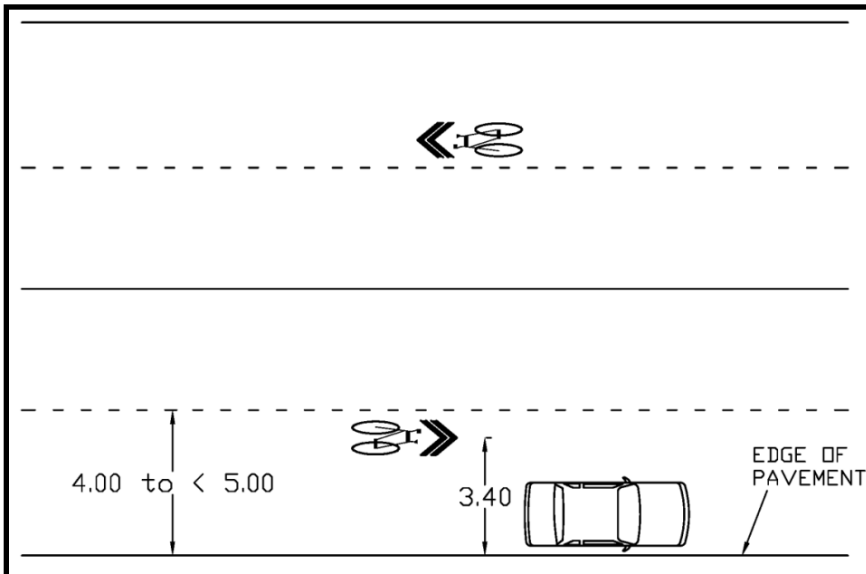
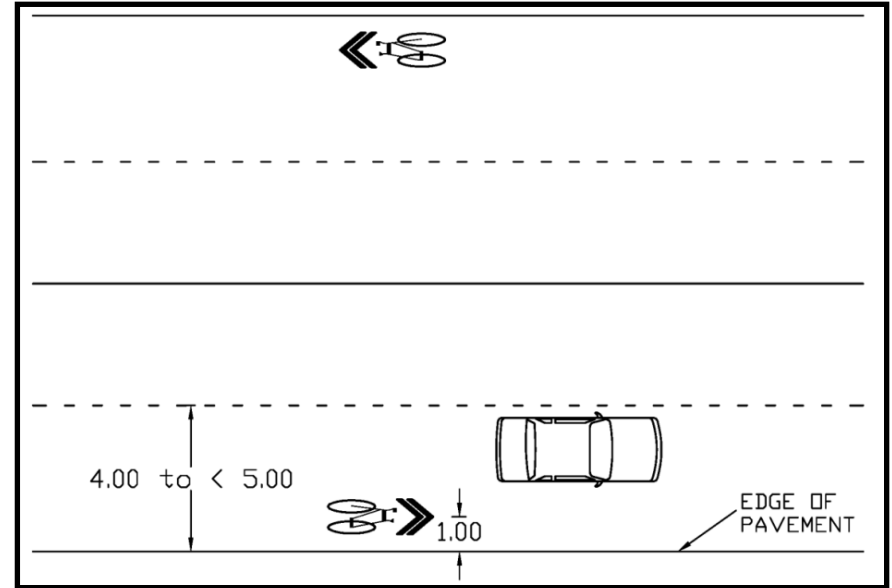

With On-street

Parking



Offset encourages cyclists to maintain a clear distance from open doors of parked cars.

Paved Shoulders (Shared Space)

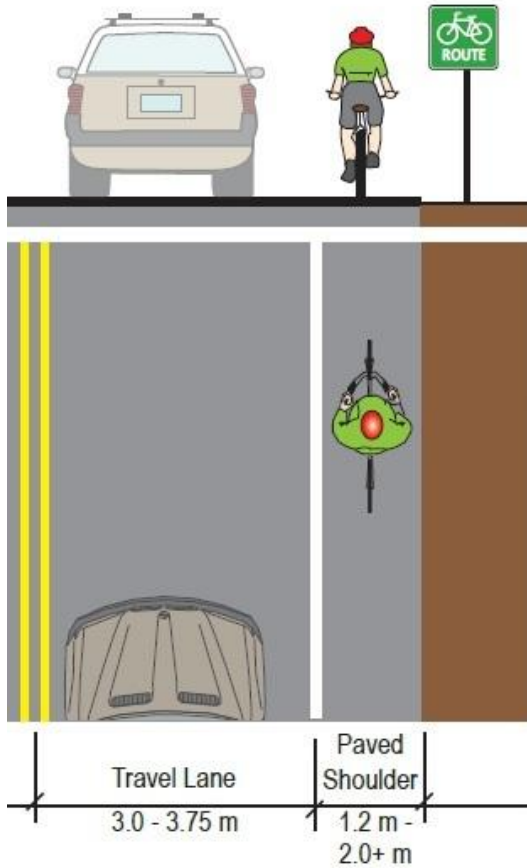

Provide a space for cyclists on rural cross-section roads (with shoulders, no curb and gutter).

Where motor vehicle speeds or volumes are high, a wider shoulder and/or painted buffer enables more separation between the cyclist and motor vehicle, and also reduces the impact of wind-shear on the cyclist.

Rumble strips can be added to the painted buffer as an additional cue, provided that there are clearly marked breaks at regular intervals, allowing cyclists to move in or out of the paved shoulder area to overtake slower moving cyclists or to make a left turn.

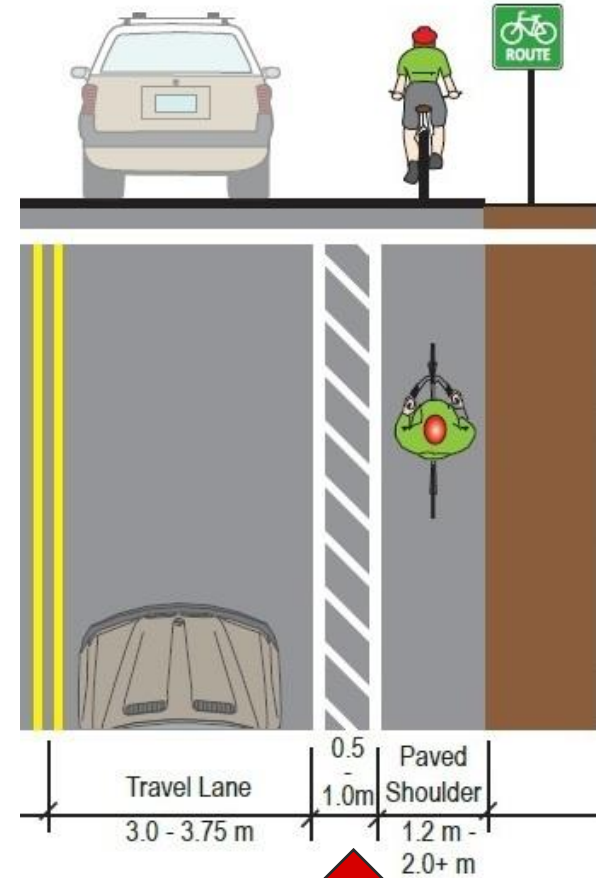

Painted buffer where motor vehicle speed and/or volume are high



Bike Lanes (Dedicated Space)

A dedicated facility located in the travelled portion of the roadway for one-way cyclist traffic.

Motor vehicles are not typically allowed to drive, park or stand in a bike lane, but right turning motor vehicles can enter the lane at intersections to complete their turn.

Ensuring consistency in the design and signing of bike lanes and other bikeway facilities is crucial to educate and inform cyclists and motorists on their proper use.

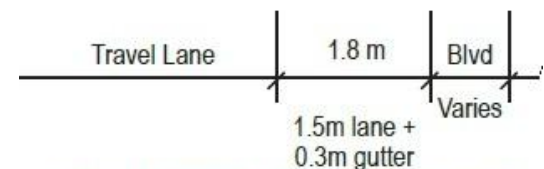
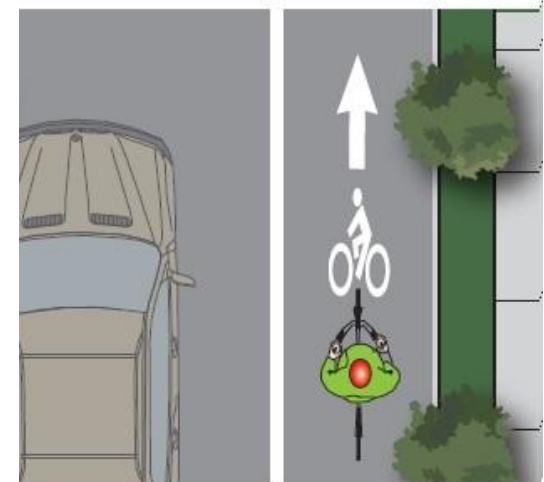
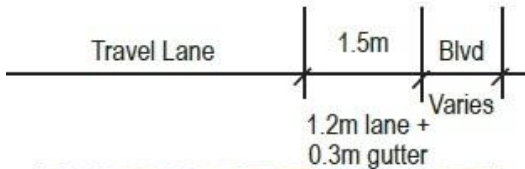
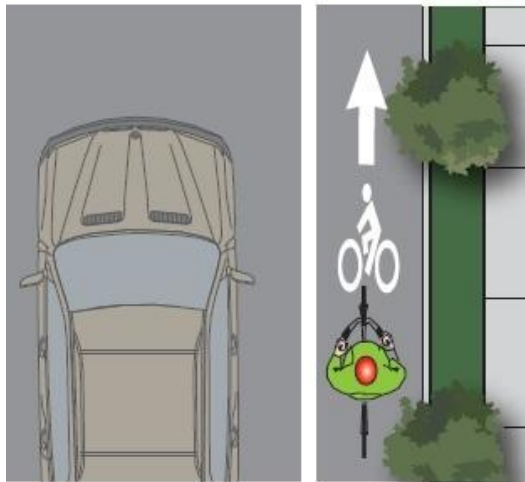

A wider bike lane is needed beside parked cars

Retro-fitting

Georgetown, ON:

- 4 lane collector
- On-street parking permitted, but low demand
- High operating speeds



15.75m
Existing

Scenario 1

Bike lanes with on-street parking one side



2.45m	1.8m	3.5m	3.0m	3.5m	1.5m
PARKING	BIKE LANE	TRAVEL LANE	CENTRE LEFT TURN LANE	TRAVEL LANE	BIKE LANE

Scenario 2

Bike lanes with on-street parking two sides



Example of Suggested Minimum Facility Type and Widths

Source: Minnesota DOT Bikeway Facility Design Manual, March 2007

Bikeway Design Selection for Urban (Curb and Gutter) Cross Section Roads							
Motor Vehicle ADT (2 Lane)		<500	500-1,000	1,000-2,000	2,000-5,000	5,000-10,000	>10,000
Motor Vehicle ADT (4 Lane)		N/A	N/A	2,000-4,000	4,000-10,000	10,000-20,000	>20,000
Motor Vehicle Speed	40 km	SL	WOL	WOL	WOL	BL=1.5m	Not Applicable
	50 km	SL with sign	WOL	BL=1.5m	BL=1.5m	BL=1.8m	BL=1.8m
	60 km	WOL	BL=1.5m	BL=1.5m	BL=1.8m	BL=1.8m	BL=1.8m or PS=2.4m
	70+ km	BL=1.5m	BL=1.5m	BL=1.8m	BL=1.8m	BL= 1.8m or PS=2.4m	SUP or PS=3.0m
BL= Bicycle Lane, SL=Shared Lane, WOL= Wide Outside/Curb Lane, SUP= Shared-Use Path, PS= Paved Shoulder							

Buffered Bike Lanes (Dedicated Space)



Buffered Bike Lane
Toronto, ON

Buffered bike lanes provide additional space/separation between the cyclist and motor vehicles.

They should be considered on high volume, higher speed roads.

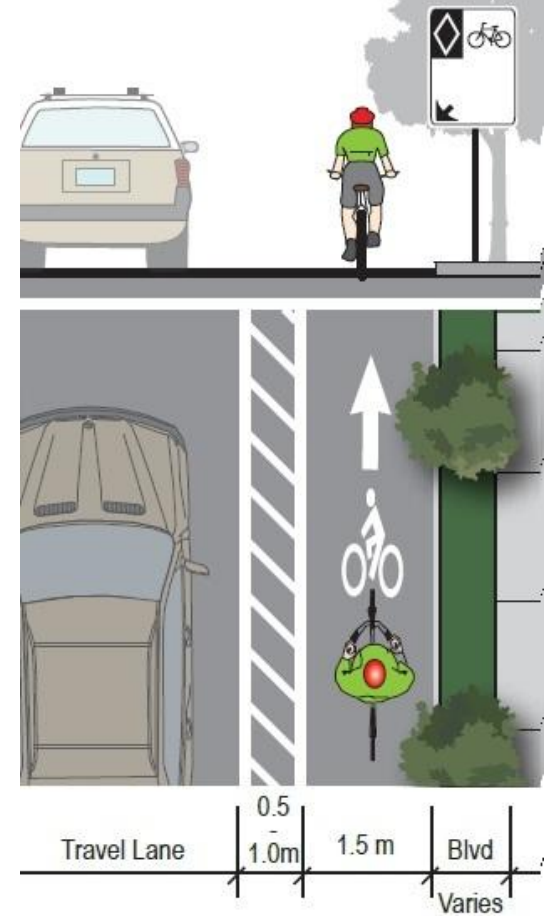

Cycle Tracks (Separated Facility)

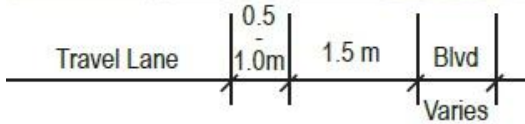
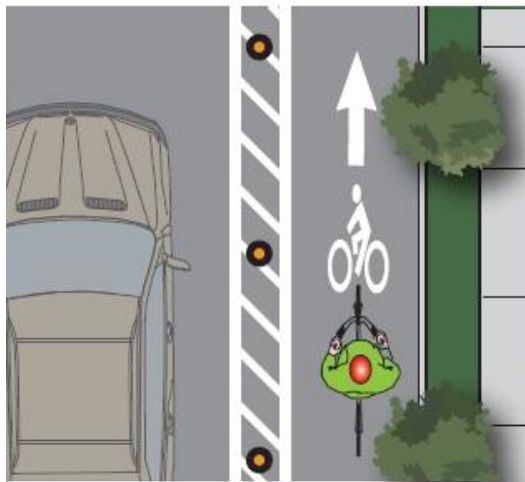

A bicycle facility that combines the user experience of a separated path with the on-road infrastructure of a conventional bike lane.

Cycle tracks provide space that is intended to be exclusively or primarily for bicycles, and are separated from motor vehicle travel lanes using different design techniques such as parking lanes, bollards, curbs, medians or a combination thereof.

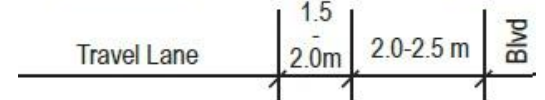
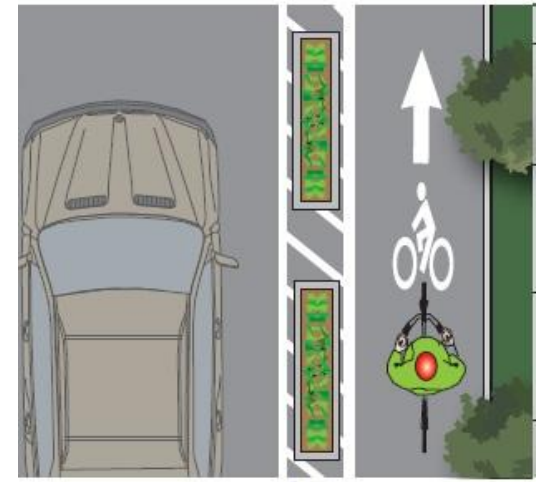

Painted buffer and flexible/removable bollards create separation



Painted buffer and planter boxes creates separation



Cycle Tracks (Separated Facility)

Cycle tracks can be either one-way or two-way, on one or both sides of a street, and are separated from vehicles and pedestrians by pavement markings or coloring, bollards, curbs/medians or a combination of these elements.

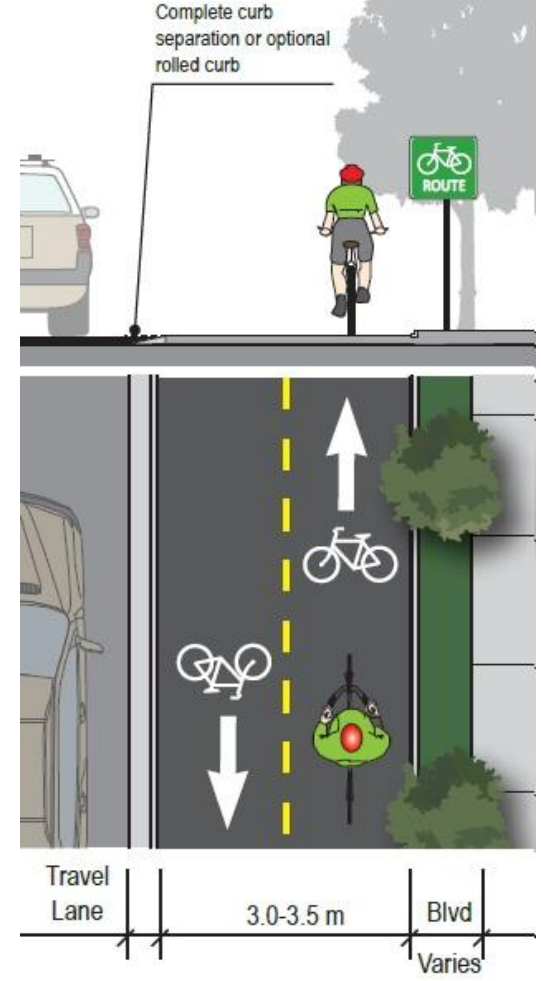
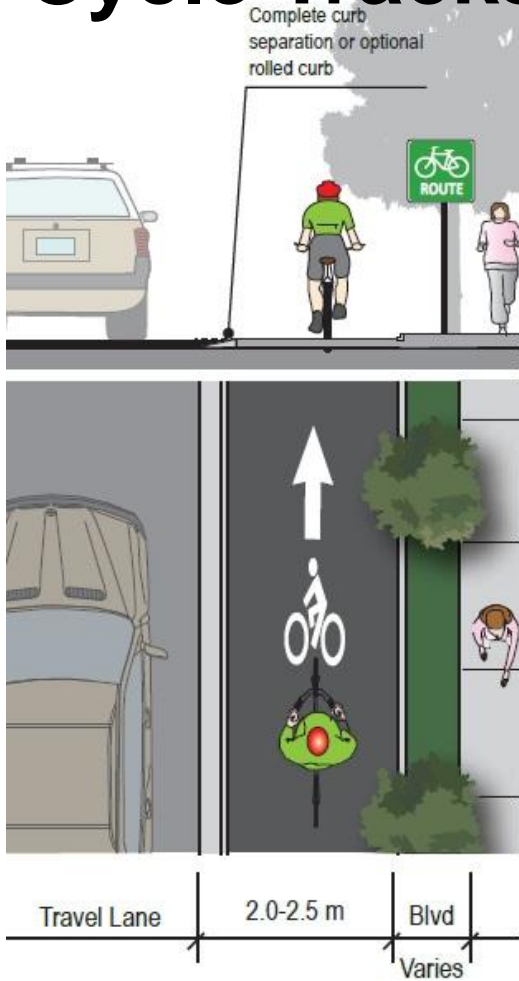

Two-way Cycle Track



One-way CycleTrack with rolled curb



Cycle Tracks (Separated Facility)

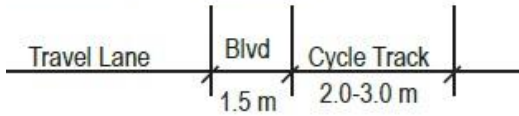
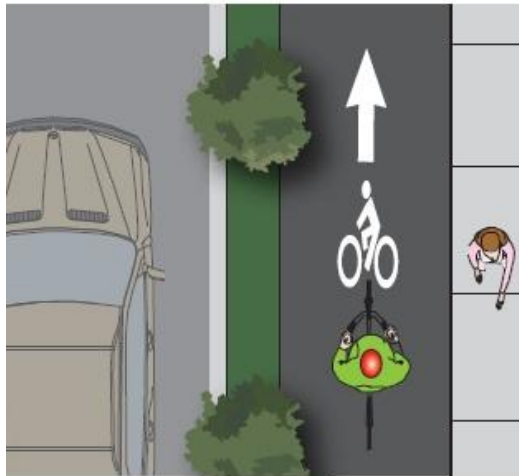

One-way
CycleTrack with
landscaped
median for
separation

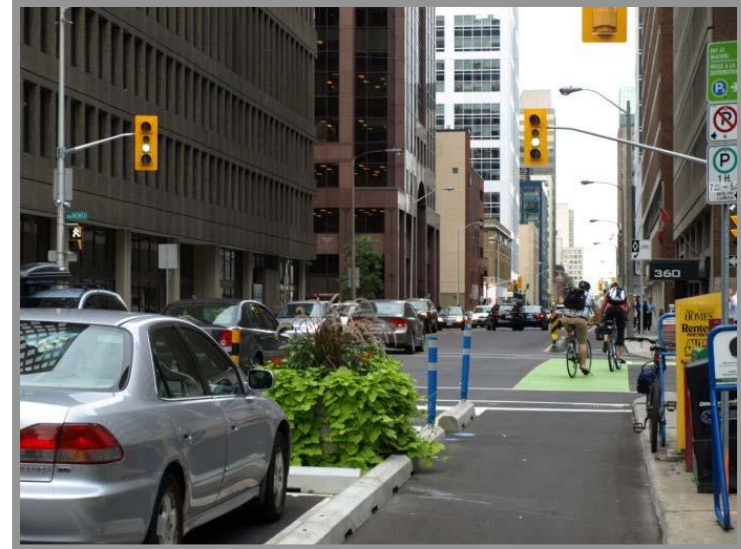

Laurier Ave., Ottawa, ON

Separated Cycling Facility Pilot Project, implemented in 2011. Utilizes painted buffers, painted buffers with flexible bollards, removeable barrier curbs, and planter boxes in various locations along corridor.

Painted zones at intersections assist cyclists with 2-stage left turns.



Cycle Tracks (Separated Facility)

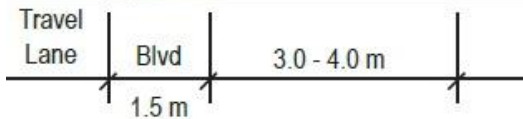
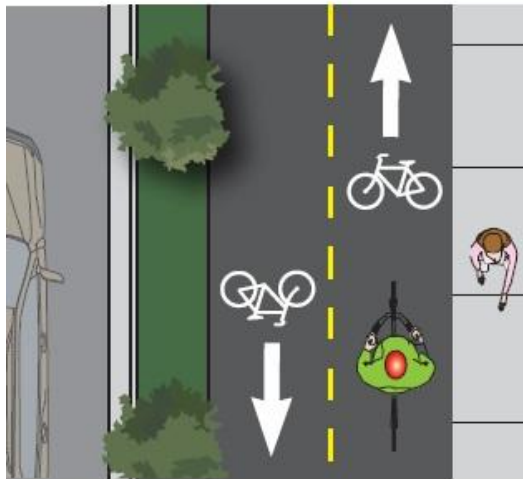

**Two-way
CycleTrack with
landscaped median
for separation**

Emergency vehicle access, access to transit stops, access for para-transit vehicles, winter maintenance and snow storage are all important considerations when designing cycle tracks.



**Two-way
CycleTrack with on-
street parking as a
buffer**



Montreal, PQ

In-Boulevard Multi- use Pathways (Separated Facility)

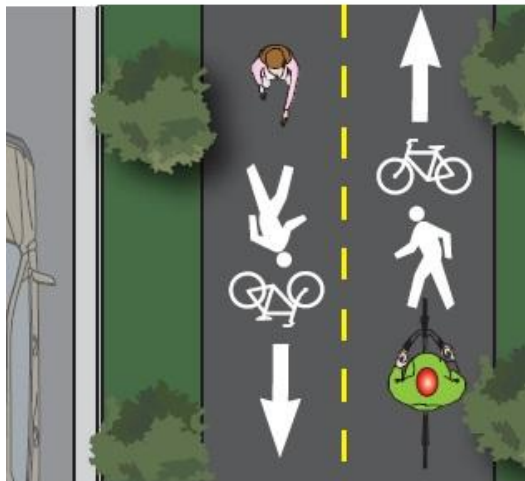

In-boulevard multi-use pathways (within road rights-of-way) are useful for both pedestrians and cyclists along popular commuter routes. They can be used in place of a sidewalk.

A good facility type where there is ample right-of-way, a low frequency of intersections and driveways, and adjacent land use or lotting pattern that minimizes the potential for conflict with pedestrians.

Not a good choice for high density development with narrow frontages.



Multi-Use Boulevard Trail
Aurora, ON

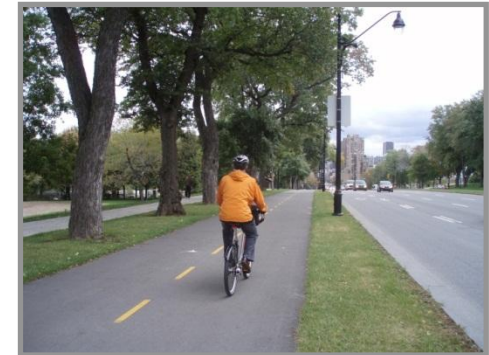

Multi-Use Boulevard Trail
Toronto, ON



Multi-use Pathways outside of Road Rights-of Way (Separated Facility)



Multi-use pathways outside of the road right-of-way are an integral part of a comprehensive cycling network.



Placed in greenway corridors and other linear corridors (hydro, gas, light rail and low volume rail), these provide critical connections for recreational, novice and child cyclists.

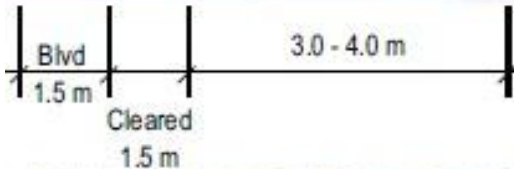

Etobicoke Creek Trail
Mississauga, ON



Trans Canada Trail
Peterborough, ON



Thames Valley Parkway
London, ON



Multi-Use Trail with Rail
Guelph, ON



Summary

The **Bicycle Facility Selection Guide** can be used to assist Town staff in selecting appropriate bicycle facilities for Town-owned local and collector road rights-of-way.

- There is no “formula” for appropriate bicycle facility selection; and
- It is a process that combines an analysis and understanding of the conditions of the location being considered with sound engineering judgement.

Step 1

Pre-selection
Nomograph

Step 2

Examine Other
Factors

Step 3

Select Appropriate
Facility Type