

Memorandum to the City of Markham Committee of Adjustment

October 26, 2020

File: A/096/20
Address: 61 Busch Ave – Markham, ON
Applicant: Jassar Balvinder Singh
Agent: YEJ Studio and Consulting Inc.
Hearing Date: November 4, 2020

The following comments are provided on behalf of the West Team. The applicant is requesting relief from the following requirement of the “Residential Two – R2*456” zone under By-law 177-96, as amended, to permit:

a) **By-law 177-96, Section 6.5:**

an accessory dwelling unit (basement apartment), whereas the By-law does not permit an accessory dwelling unit.

BACKGROUND

Property Description

The 352.0 m² (3,788.90 ft²) subject property is located on the south side of Busch Avenue, north of 16th Avenue, south of Wilfred Murison Avenue, and west of William Berczy Boulevard. There is an existing two-storey single detached dwelling with a two-car garage and a driveway which can accommodate parking for up to four vehicles. The property is located within an established residential neighbourhood which contains a mix of two-storey single detached, semi-detached dwellings, and two to three-storey townhouse dwellings.

Proposal

The applicant is requesting permission for a secondary suite in the basement of the existing dwelling. The proposal includes a new egress window at the west side of the building. The proposed secondary suite would have direct and separate access provided by a new door accessed by a walk-up located at the south side (rear) of the building. No other changes are being proposed to the exterior of the dwelling or the property.

Provincial Policies

More Homes, More Choice Act, 2019

The *More Homes, More Choice Act, 2019*, S.O. 2019, c. 9 – (Bill 108), received Royal Assent on June 6, 2019 and portions were proclaimed on September 3, 2019. The proclaimed portions of Bill 108 amended the *Planning Act* to require Official Plans to contain policies providing for two residential units in detached, semi-detached and rowhouse dwellings, as well as permitting a residential unit in ancillary structures to a detached, semi-detached, or rowhouse dwelling. Under this legislation, “second suites” or “secondary suites” are now referred to as “additional residential units”, and the terms are used synonymously in this memorandum.

Provincial Policy Statement, 2020

Section 1.4.3 of the *Provincial Policy Statement, 2020*, requires planning authorities to provide for an appropriate range and mix of housing options and densities to meet the affordable housing needs of current and future residents. Amongst other means, this can

be achieved by permitting and facilitating residential intensification, including additional residential units, and redevelopment by accommodating a significant supply and range of housing options through intensification and redevelopment while taking into account existing building stock.

A Place to Grow: Growth Plan for the Greater Golden Horseshoe, 2019 (Growth Plan, 2019)

Section 2.1.4 (c) of the *Growth Plan, 2019* requires municipalities to provide a diverse range and mix of housing option including second units to support complete communities.

Official Plan and Zoning

2014 Official Plan (partially approved on Nov 24/17 and updated on April 9/18)

The City's Official Plan designates the subject property "Residential Low Rise", which provides for low rise housing forms including single detached dwellings. The Official Plan also contains criteria for the establishment of secondary suites in Section 8.13.8 which states:

"That in considering an application to amend the Zoning By-law to permit the establishment of a secondary suite where provided for in this Plan, Council shall be satisfied that an appropriate set of development standards are provided for in the Zoning By-law including:

- a) the building type in which the secondary suite is contained;*
- b) the percentage of the floor area of the building type devoted to the secondary suite;*
- c) the number of dwelling units permitted on the same lot;*
- d) the size of the secondary suite;*
- e) the applicable parking standards; and*
- f) the external appearance of the main dwelling."*

A "Secondary Suite" in the Official Plan is defined as:

"...a second residential unit in a detached house, semi-detached house or rowhouse that consists of one or more rooms designed, occupied or intended for use, including occupancy, by one or more persons as an independent and separate residence in which a facility for cooking, sleeping facilities and sanitary facilities are provided for the exclusive use of such person or persons."

Section 4.1.2.6 of the Official Plan contains policies to support further diversification of the housing stock and rental housing tenure by permitting secondary suites within existing and new single detached, semi-detached and rowhouse dwellings in accordance with Section 3.5.22 of the Regional Official Plan and subject to appropriate zoning, development criteria, and standards.

Zoning By-Law 177-96

The subject property is zoned "Residential Two – R2*456" under By-law 177-96, as amended, which permits the following dwelling types: single detached, semi-detached, duplex, triplex, fourplex, or townhouse.

Zoning Preliminary Review (ZPR) Not Undertaken

The applicant has confirmed that a ZPR has not been conducted. However, the applicant has received comments from the building department through their building permit process to confirm the variance required for the proposed development.

COMMENTS

The *Planning Act* states that four tests must be met in order for a variance to be granted by the Committee of Adjustment (“the Committee”):

- a) The variance must be minor in nature;
- b) The variance must be desirable, in the opinion of the Committee of Adjustment, for the appropriate development or use of land, building or structure;
- c) The general intent and purpose of the Zoning By-law must be maintained;
- d) The general intent and purpose of the Official Plan must be maintained.

Secondary Suites

Fire and Emergency Services Department has no objections provided the secondary suite is registered with the City and complies with Building and Fire Codes. Should this application be approved, the applicant will be required to obtain a building permit which ensures the secondary suite will be in compliance with Building Code and Fire Code regulations, and will be required to register their secondary suite with the Fire Department prior to occupancy of the secondary suite.

The City of Markham is committed to promoting affordable and shared housing opportunities. Secondary suites help the City increase the availability of affordable housing forms and provide support to achieve its affordable housing target required by the Province. Planning staff are of the opinion that the application meets the criteria under Section 8.13.8 of the Official Plan for the establishment of a secondary suite and support its approval.

Tree Protection

The City of Markham’s Urban Forestry staff have reviewed the application, and recommend that appropriate tree protection hoarding or snow fencing be installed around the City owned tree prior to undertaking any potential works related to landscaping, construction, or demolition to ensure that no temporary storage of materials is permitted within the tree protection zone.

PUBLIC INPUT SUMMARY

No written submissions were received as of October 26, 2020. It is noted that additional information may be received after the writing of the report, and the Secretary-Treasurer will provide information on this at the meeting.

CONCLUSION

Planning staff have reviewed the application with respect to Section 45(1) of the *Planning Act, R.S.O. 1990, c. P.13, as amended*, and are of the opinion that the variance request meets the four tests of the *Planning Act* and support its approval. Staff recommend that the Committee consider public input in reaching a decision.

The onus is ultimately on the applicant to demonstrate why they should be granted relief from the requirements of the By-law, and how they satisfy the tests of *the Planning Act* required for the granting of minor variances.

Please see Appendix "A" for conditions to be attached to any approval of this application.

APPENDICES

Appendix "A" – Conditions of Approval

Appendix "B" – Plans

PREPARED BY:



Aleks Todorovski, Planner, Zoning and Special Projects

REVIEWED BY:

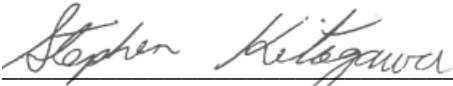

Stephen Kitagawa, Acting-Development Manager, West District

APPENDIX "A"

CONDITIONS TO BE ATTACHED TO ANY APPROVAL OF FILE A/096/20

1. The variances apply only to the proposed development as long as it remains.
2. That the variances apply only to the subject development, in substantial conformity with the batch stamped plans attached as Appendix "B" to this Staff Report, and that the Secretary-Treasurer receive written confirmation from the Director of Planning and Urban Design or designate that this condition has been fulfilled to his or her satisfaction.
3. That the owner submit, if required by the Chief Building Official, a third-party report prepared by an architect or professional engineer licensed in the Province of Ontario, to assess compliance of existing construction with the provisions of the Ontario Building Code, and in particular relating to the change of use from a dwelling containing a single suite to a dwelling containing more than one suite.
4. That prior to the commencement of landscaping, construction, or demolition, tree protection hoarding or snow fencing be erected and maintained around the City owned street tree on site, in accordance with the City's Streetscape Manual (2009), as amended, which is to be inspected by City Staff to the satisfaction of the Tree Preservation Technician or Director of Operations.

CONDITIONS PREPARED BY:



Aleks Todorovski, Planner, Zoning and Special Projects

APPENDIX "B"
PLANS TO BE ATTACHED TO ANY APPROVAL OF FILE A/096/20

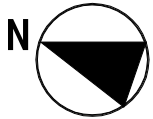

BUSCH AVE

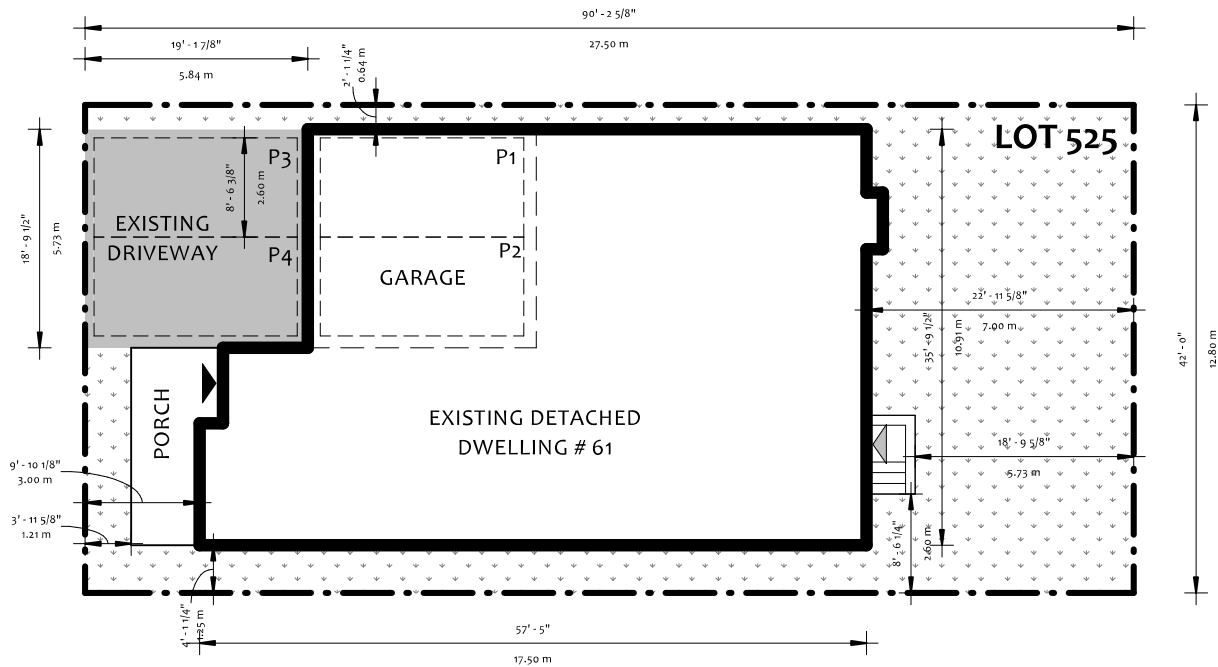

Appendix B

File: 20.129232.000.00.MNV

Date: 10/29/20

MM/DD/YY

- UNIT 1 MAIN ENTRANCE
- UNIT 2 ENTRANCE

7-250 SHEILDS CRT.
MARKHAM ON L3R 9T5
888.236.9958 | 416.483.5393
INFO@YEJSTUDIO.COM
WWW.YEJSTUDIO.COM

BASEMENT SECOND UNIT

61 BUSCH AVE,
 MARKHAM,
 ON L0C 0V4

THE UNDERSIGNED HAS REVIEW AND TAKES RESPONSIBILITY FOR THE DESIGN, AND HAS THE QUALIFICATIONS AND MEETS THE REQUIREMENTS SET OUT IN THE ONTARIO BUILDING CODE TO BE A DESIGNER.

QUALIFICATION INFORMATION

REQUIRED UNLESS DESIGN IS EXEMPT UNDER 3.2.5.1 OF DIVISION "C" OF O.B.C.

NAME AMR ROBAH		BCIN 42582
-------------------	--	---------------



CLIENT REVIEW	
REVISION	
ISSUED FOR PERMIT	

SITE PLAN		A-02
Drawn by	T.L	
Project number	20 RE 500-212	
Date	2020.9.30	Scale 3/32" = 1'-0"

Appendix B

File: 20.129232.000.00.MNV
 Date: 10/29/20
 MM/DD/YY

Http://WeDoBuildingPermits.ca
 289-946-0997

ISSUE	BY	DESCRIPTION	DATE YY-MM-DD
GENERAL NOTES: DO NOT SCALE DRAWINGS. VERIFY CONFIGURATIONS & DIMENSIONS ON SITE BEFORE BEGINNING WORK. NOTIFY ARCHITECT/ENGINEER IMMEDIATELY OF ANY ERRORS, OMISSIONS OR DISCREPANCIES.			
THE UNDERSIGNED HAS REVIEWED AND TAKES RESPONSIBILITY FOR THIS DESIGN, AND HAS THE QUALIFICATIONS AND MEETS THE REQUIREMENTS SET OUT IN THE ONTARIO BUILDING CODE TO DESIGN THE WORK SHOWN ON THE ATTACHED DOCUMENTS.			
QUALIFICATION INFORMATION			
NAME	PANKAJ BHATIA	SIGNATURE	BCIN 101562
REGISTRATION INFORMATION			
FIRM NAME	SAI ITEM CONSULTING INC.	BCIN	110355
PROFESSIONAL CERTIFICATION			
PROJECT			
61 BUSCH AVE MARKHAM, ON L6C 0V4 CANADA			
DRAWING TITLE			
BASEMENT FLOOR PLAN - PROPOSED			
DATE	JULY 2020	ISSUED FOR	BUILDING PERMIT
DRAWN BY	SM	CHECKED BY	PB
PROJECT No.			
SCALE	AS NOTED		
A-1			

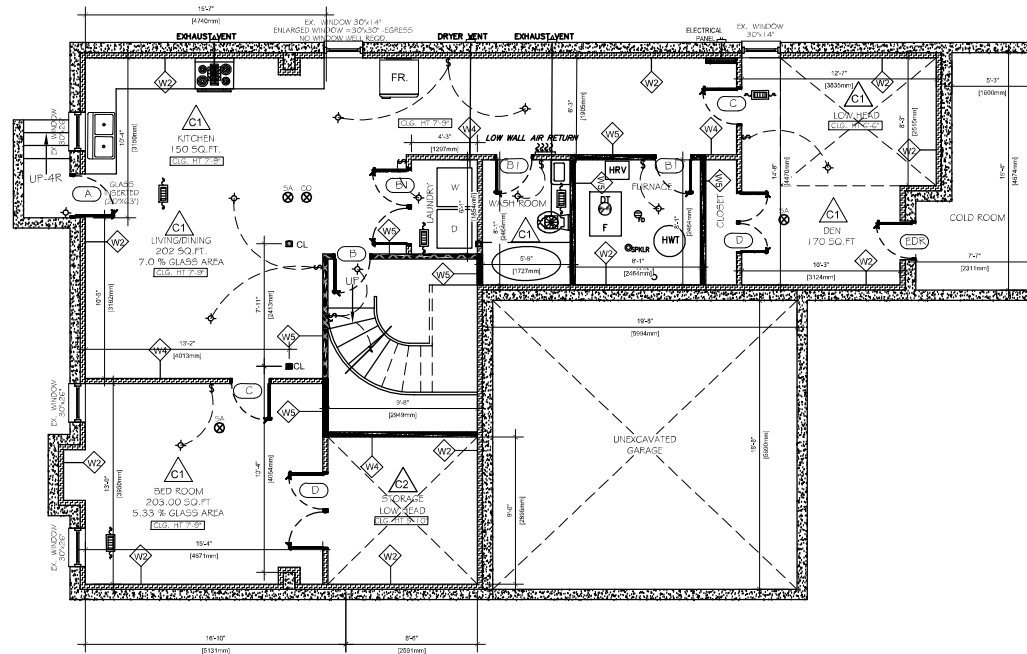

1 BASEMENT FLOOR PLAN - PROPOSED
 A-1 SCALE = 1/8" = 1'-0"

Appendix B

File: 20.129232.000.00.MNV
 Date: 10/29/20
 MM/DD/YY

Http://WeDoBuildingPermits.ca
 289-946-0997

ISSUE	BY	DESCRIPTION	DATE YY-MM-DD

GENERAL NOTES:
 DO NOT SCALE DRAWINGS. VERIFY CONFIGURATIONS & DIMENSIONS ON SITE BEFORE BEGINNING WORK.
 NOTIFY ARCHITECT/ENGINEER IMMEDIATELY OF ANY ERRORS, OMISSIONS OR DISCREPANCIES.

THE UNDERSIGNED HAS REVIEWED AND TAKES RESPONSIBILITY FOR THIS DESIGN, AND HAS THE QUALIFICATIONS AND MEETS THE REQUIREMENTS SET OUT IN THE ONTARIO BUILDING CODE TO DESIGN THE WORK SHOWN ON THE ATTACHED DOCUMENTS.

QUALIFICATION INFORMATION
 NAME: PANKAJ BHATIA
 SIGNATURE: *Pankaj Bhatia*
 BCN: 101562

REGISTRATION INFORMATION
 FIRM NAME: SAI ITPM CONSULTING INC.
 BCN: 110355

PROFESSIONAL CERTIFICATION



PROJECT
 61 BUSCH AVE
 MARKHAM, ON L6C 0V4
 CANADA

DRAWING TITLE
 GROUND FLOOR PLAN - EXISTING

DATE: JULY 2020 ISSUED FOR BUILDING PERMIT

DRAWN BY: SM	CHECKED BY: PB	SHEET NO.:
PROJECT No.:		A-2
SCALE: AS NOTED		

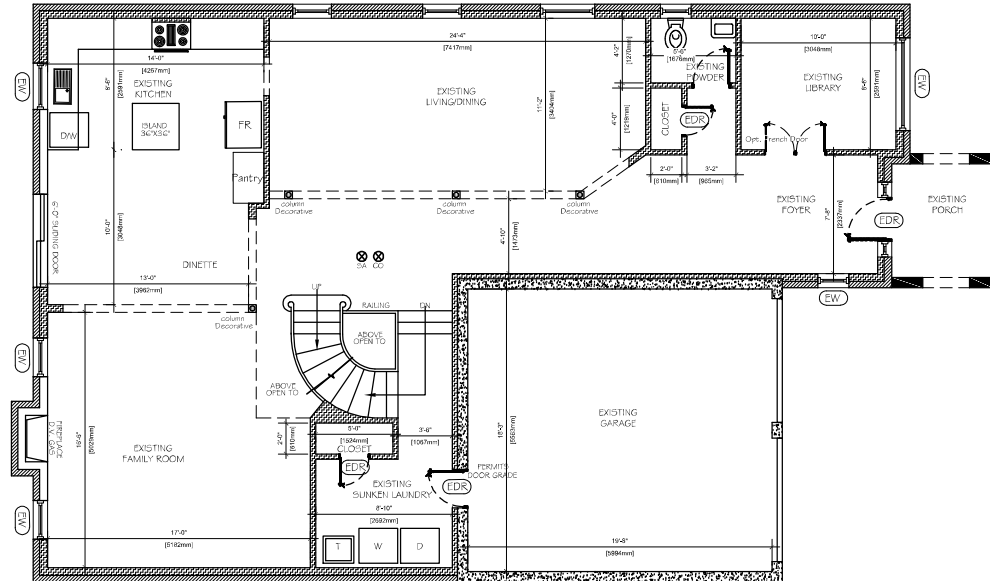

1
 A-2 GROUND FLOOR PLAN - EXISTING
 SCALE = 1/8" = 1'-0"

Http://WeDoBuildingPermits.ca
289-946-0997

ISSUE	BY	DESCRIPTION	DATE YY-MM-DD

GENERAL NOTES:
DO NOT SCALE DRAWINGS. VERIFY CONFIGURATIONS & DIMENSIONS ON SITE BEFORE BEGINNING WORK. NOTIFY ARCHITECT/ENGINEER IMMEDIATELY OF ANY ERRORS, OMISSIONS OR DISCREPANCIES.

THE UNDERSIGNED HAS REVIEWED AND TAKES RESPONSIBILITY FOR THIS DESIGN, AND HAS THE QUALIFICATIONS AND MEETS THE REQUIREMENTS SET OUT IN THE ONTARIO BUILDING CODE TO DESIGN THE WORK SHOWN ON THE ATTACHED DOCUMENTS.

QUALIFICATION INFORMATION
Pankaj Bhatia
NAME: PANKAJ BHATIA SIGNATURE: [Signature] BCN: 101562

REGISTRATION INFORMATION
FIRM NAME: SAI ITPM CONSULTING INC. BCN: 110355

PROFESSIONAL CERTIFICATION
N
PROJECT NORTH

PROJECT
61 BUSCH AVE
MARKHAM, ON L6C 0V4
CANADA

DRAWING TITLE
REAR ELEVATION

DATE: JULY 2020 ISSUED FOR: BUILDING PERMIT

DRAWN BY: SM CHECKED BY: PB SHEET NO. A6

PROJECT No. SCALE: AS NOTED



1 REAR ELEVATION
A-6 SCALE= 1/8" = 1'-0"

Appendix B

File: 20.129232.000.00.MNV

Date: 10/29/20

MM/DD/YY

Appendix B

File: 20.129232.000.00.MNV
 Date: 10/29/20
 MM/DD/YY

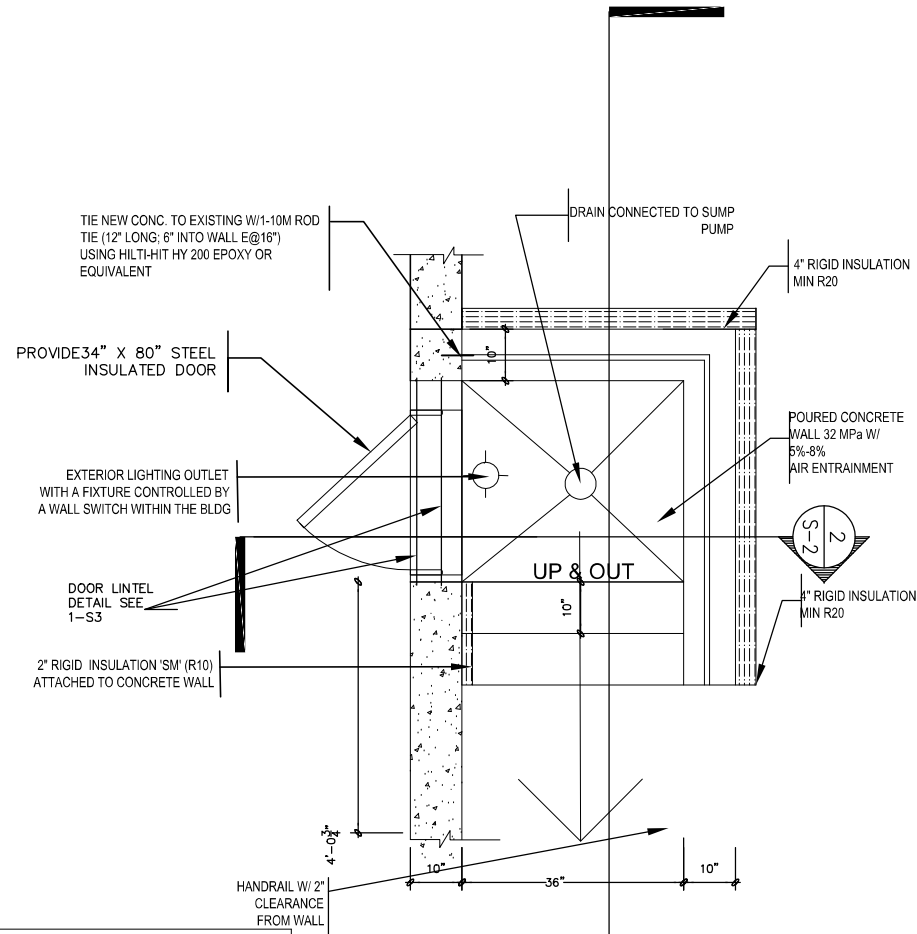

NOBLE ELITE SOLUTIONS LTD.

SPECIFICATIONS		
STAIRS	860	MM MIN WIDTH
RISERS	200	MM MAX
RUN	210	MM MIN
TREAD	235	MM MIN
HANDRAILS	900	MM (MIN) OVER STAIRS
	1075	MM (MIN) OVER LANDINGS

1 S-2
 1 S-1
 SCALE = 1/2" = 1'-0"

PROJECT NORTH		PROFESSIONAL CERTIFICATION
PROJECT		
61 Busch Ave Markham ON L6C 0V4 Canada		
DRAWING TITLE		
PLAN		
DATE JUNE 2020	ISSUED FOR BUILDING PERMIT	
DRAWN BY PB	CHECKED BY PB	SHEET NO.
PROJECT No.		S-1
SCALE As Noted		

Appendix B

File: 20.129232.000.00.MNV

Date: 10/29/20

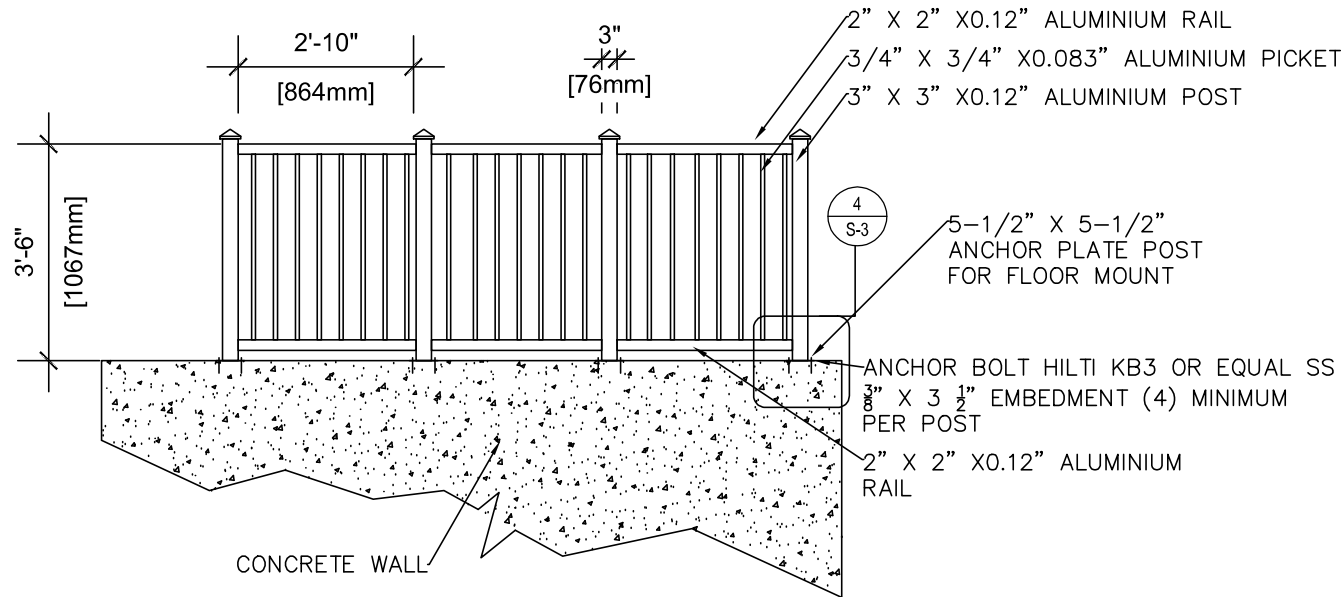

1 GUARD RAIL DETAILS
S-4 SCALE= 1/2" = 1'-0"

GENERAL NOTES : TO CONFORM TO OBC. 2012. B.4.1.5.14.

1. ALL WORKMANSHIP AND MATERIALS SHALL BE IN ACCORDANCE WITH THE ONTARIO BUILDING CODE AND REGULATIONS.
2. MATERIALS SHALL BE AS FOLLOWS:
 - 2.1. CONCRETE 32 MPa AT 28 DAYS WITH 5% TO 8% AIR ENTRAINMENT.
 - 2.2. REINFORCEMENT STEEL, CSA G30, 18M. GRADE 400
 - 2.3. BACKFILL TO BE OPS GRANULAR B1, CR SUITABLE EXCAVATED MATERIAL
3. ELECTRIC FEED FOR THE LIGHT TO BE SEPARATE FROM ANY OTHER SWITCHED CIRCUIT.
4. EXTERIOR DOOR SHALL CONFORM TO STANDARD AS PER OBC AND RESIST FORCE ENTRY

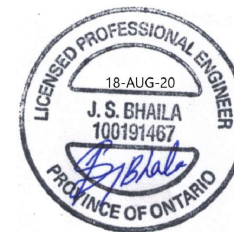

NOBLE ELITE SOLUTIONS LTD.

PROJECT NORTH		PROFESSIONAL CERTIFICATION
PROJECT		
61 Busch Ave Markham ON L6C 0V4 Canada		
DRAWING TITLE		
GUARD DETAILS		
DATE	ISSUED FOR BUILDING PERMIT	
JUNE 2020		
DRAWN BY	CHECKED BY	SHEET NO.
PB	PB	S-4
PROJECT No.		
SCALE	AS NOTED	